

MODEL: A1250LP  
SEPTIC

TANK SPECIFICATIONS:

Dimensions:

Walls: 3"  
Bottom: 5"  
Cover: 6"  
Height: 49-1/2" O.D.  
Length: 136" O.D.  
Width: 84" O.D.  
Distance Below Inlet: 38" O.D.  
Distance Below Outlet: 35" O.D.  
Liquid Level: 30"  
Weight: 13,660 LBS

Manhole:

24" I.D. - All Manholes come Standard  
With a Riser Coupler that will accept  
Concrete or Plastic Riser Rings

Inlet & Outlet:

4" Bore with a Polyloc Poly III CE Seal  
or equal.

Baffles:

Inlet: 14"  
Outlet: 20"  
Baffle clearance to cover 1"

Liquid Capacity: 42.05Gal/In

Max Burial: 7'-0"

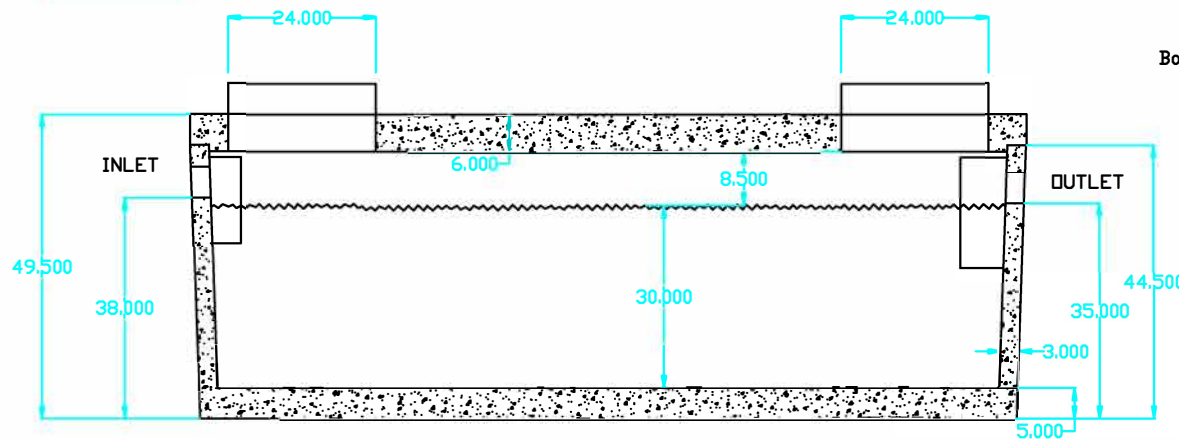

A TCC MATERIALS COMPANY

AMCON BLOCK & PRECAST  
8644 RIDGEWOOD ROAD  
ST. JOSEPH, MN.  
1-320-251-6031  
1-866-251-6031  
CENTRAL DISPATCH  
Toll Free: 1-800-876-6030

MANUFACTURE DATE: \_\_\_\_\_