

MODEL: A1500LPL
1000/500
SEPTIC/PUMP

TANK SPECIFICATIONS:

Dimensions:
 Walls: 3'
 Bottom: 5'
 Cover: 6'
 Height: 49-1/2' O.D.
 Length: 166' O.D.
 Width: 84' O.D.
 Distance Below Inlet: 38' O.D.
 Distance Below Outlet: 35' O.D.
 Liquid Level: 30'
 Weight: 17,660 LBS

Manhole:
 24" I.D. - All Manholes come Standard
 With a Riser Coupler that will accept
 Concrete or Plastic Riser Rings

Inlet & Outlet:
 4' Bore with a Polyloc Poly III CE Seal
 or equal.

Baffles:
 Inlet: 14'
 Interior Wall: 20'
 Outlet: 20'
 Baffle Clearance to cover 1'

Liquid Capacity: 33.84 Gal/In Main
16.75 Gal/In Pump

Max Burial: 7'-0"

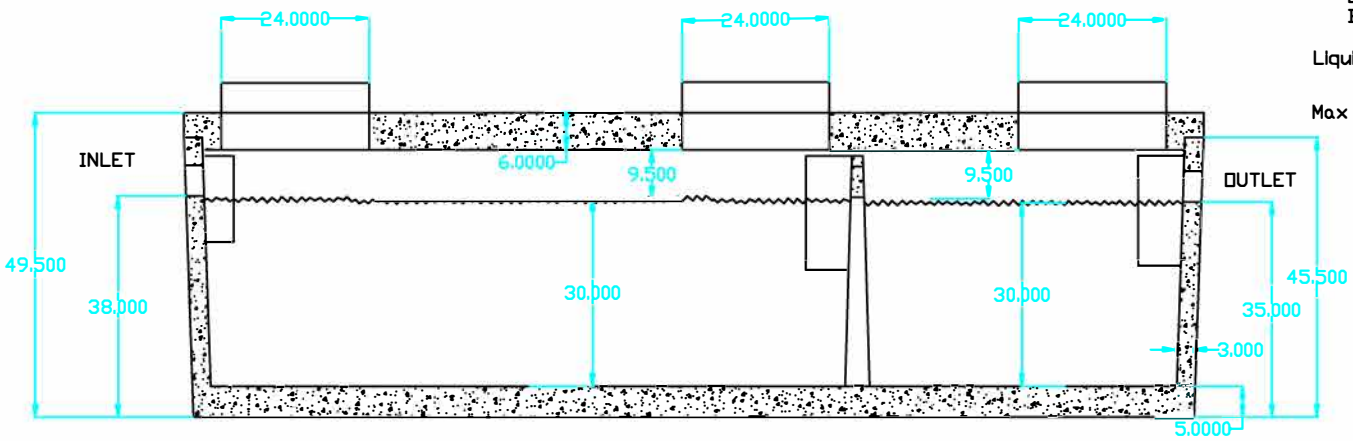

A TCC MATERIALS COMPANY

AMCON BLOCK & PRECAST
 8644 RIDGEWOOD ROAD
 ST. JOSEPH, MN.
 1-320-251-6031
 1-866-251-6031
 CENTRAL DISPATCH
 Toll Free: 1-800-876-6030

MANUFACTURE DATE: _____